



Residential Fan Coil Unit Carisma Whisper

TECHNICAL MANUAL



TABLE OF CONTENTS

Introduction

Introduction	p. 4
--------------	------

CFF-ECM

Version and main components	p. 5
-----------------------------	------

Versions	p. 6
----------	------

Main performance and technical characteristics	p. 7
--	------

Cooling emission	p. 8
------------------	------

Heating emission	p. 11
------------------	-------

Water side pressure drop	p. 14
--------------------------	-------

Operating limits	p. 15
------------------	-------

Dimensions	p. 16
------------	-------

Valves	p. 18
--------	-------

Configurations and electronic controls

Configurations and electronic controls	p. 20
--	-------

Controls

Controls	p. 21
----------	-------

Accessories

Accessories	p. 25
-------------	-------

INTRODUCTION

The Carisma Whisper CFF-ECM fan coil unit combines a reduced dimension with a modern aesthetic, while maintaining great performances in terms of sound and consumption.

Carisma Whisper CFF-ECM includes the MV version for wall installation and the IV version for concealed installation; the MV version combines a reduced dimension, up to 126 mm depth only, with a modern aesthetic that perfectly suits with any kind of furnishing, while maintaining great performances in terms of sound and consumption.

The Carisma Whisper CFF-ECM range makes use of the excellent experience gained with the fan coil units with inverter board, first in the world in production since 2009, and which have had great success on all markets. The latest synchronous inverter driven BLAC brushless and sensorless electronic motor with permanent

magnets is controlled by an Inverter board designed and developed in Italy.

The electronic board is directly fitted on the motor.

The air flow can be varied continuously with a 1-10 V signal.

The continuous air flow control improves the acoustic comfort and allows a more punctual reply to the variation of the thermal loads and a greater stability of the requested ambient temperature.

The extreme efficiency, also at a low speed, makes possible a great reduction in electric consumption with absorption values, under normal operating conditions, that are no greater than 5 Watt.

The excellent values in terms of sound levels have been maintained in all working conditions, without any resonance phenomenon at any frequency.



VERSION AND MAIN COMPONENTS

Range includes 5 air flow rates (from 75 to 645 m³/h) and 2 versions (standard with casing and for concealed installation), each one equipped with 2 row coil.

The standard versions with the casing are available in the following combinations:

- without control (CFF-ECM-MV)
- with CB-E control (CFF-ECM-MV-CB-E)
- with CB-Touch control (CFF-ECM-MV-CB-T)

The CB-E and CB-Touch versions are supplied with their power units (UP-ECO and UP-Touch) fitted on the unit.

The CB-E control must always be connected with a programmable thermostat (not supplied by us).

The Carisma Whisper CFF-ECM range is perfect to meet all air-conditioning requirements of residential and work environments like offices, shops, restaurants and hotel rooms.

Outer casing

Made of galvanized steel and with plastic outer casing

The air diffuser, that is placed over the top of the unit, is of adjustable type.

White RAL 9003.

Inner casing

Made of 1 mm galvanized steel, a rear panel and two lateral sides insulated with 3 mm polyolefin (PO) foam (class M1).

Filter

Polypropylene cellular fabric regenerating filter.

The filter frame, made of synthetic material, is inserted into special plastic sliding guides fastened to the internal structure for easy insertion and removal of the filter.

Fan assembly

Made of plastic tangential fan with anti-vibration fins.

The fan hub, dynamically and statically balanced, is directly secured onto the motor shaft.

Electric motor

Electronic motor with three phase permanent magnet brushless electronic motor that is controlled with reconstructed current according to a BLAC sinusoidal wave.

The inverter board that controls the motor operation is powered by 230 Volt, single-phase and, with a switching system, it generates a three-phase frequency modulated, wave form power supply.

The electric power supply required for the machine is therefore single-phase with voltage of 230 - 240 V and frequency of 50 - 60 Hz.

Coil

It is manufactured from drawn copper tube and the aluminium fins are mechanically bonded onto the tube by an expansion process.

The coil has two Ø 1/2 inch BSP internal connections.

The coil has Ø 1/8" inch BSP air vent and drain.

The heat exchanger is not suitable for use in corrosive atmosphere or in environments where aluminium may be subject to corrosion.

Flow and return pipe connections are situated at the same end on the left side looking at the unit. On request we can deliver the unit with the connections on the right end side: this must be specified on the order as this operation can not be carried out on site during installation.

Valves

The versions without valves or with mounted valves are available for all sizes.

The available valves are:

- 2 way
- 3 way

The valves can be ordered separately and easily installed on the basic units without valves.

Condensate collection tray

Made of plastic (ABS UL94 HB) and fixed to the internal structure. The outside diameter of the condensate discharge pipe is Ø 15 mm.



VERSIONS

Standard version with casing - MV

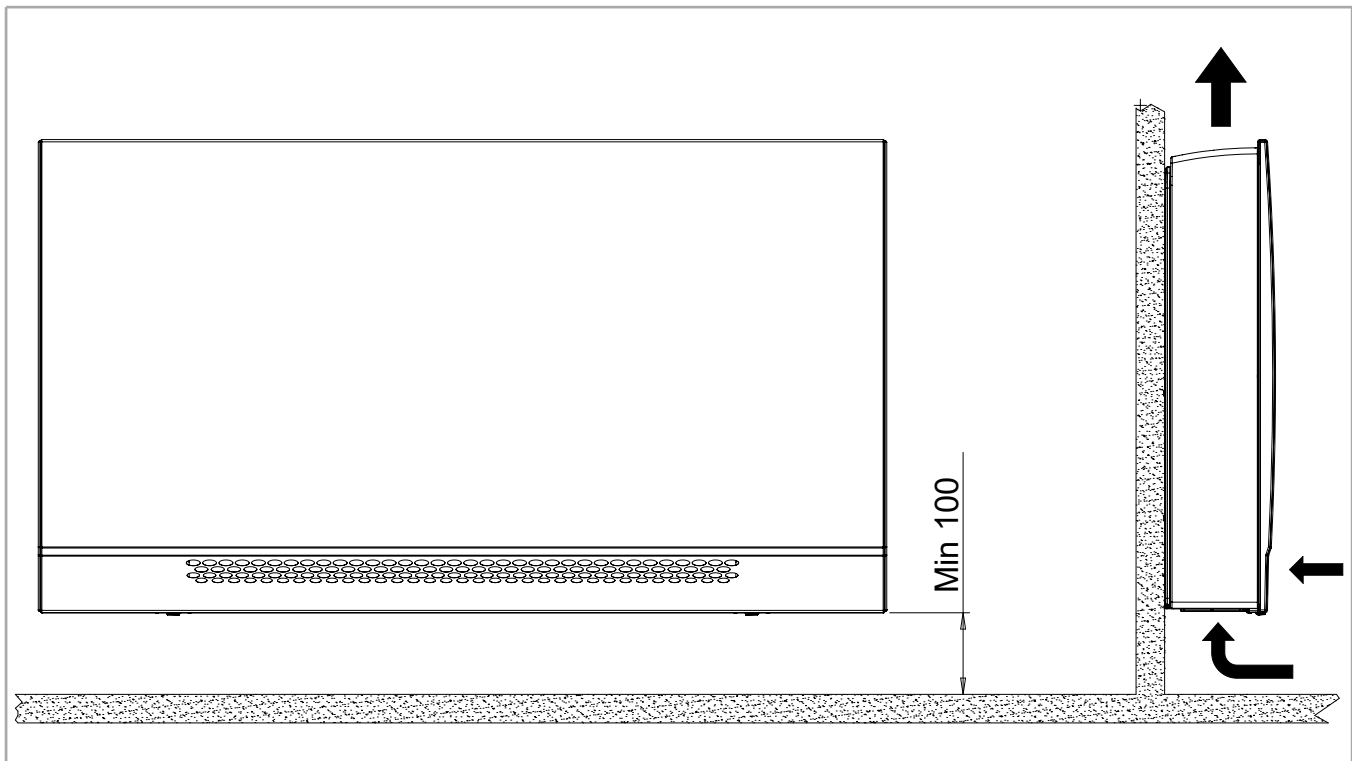

Version for concealed installation - IV

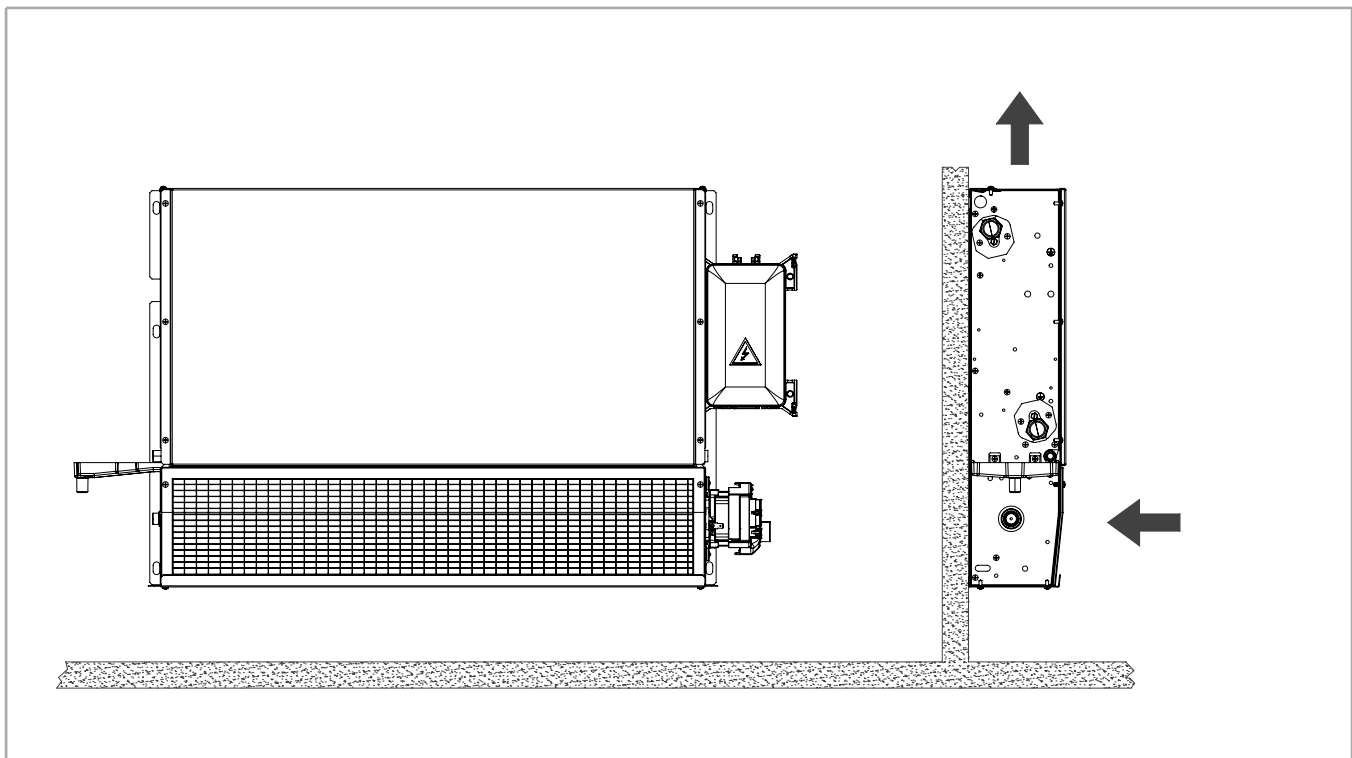

MAIN PERFORMANCE AND TECHNICAL CHARACTERISTICS

The following standard rating conditions are used:

COOLING

Entering air temperature: + 27 °C d.b. + 19 °C w.b.
Water temperature: +7 °C E.W.T. +12 °C L.W.T.

HEATING

Entering air temperature: + 20 °C
Water temperature: +45 °C E.W.T. +40 °C L.W.T.

MODEL	Inverter power	CFF-ECM 10						CFF-ECM 20						CFF-ECM 30					
		1 MIN	2	3,5	5 MED	7,5	10 MAX	1 MIN	2	3,5	5 MED	7,5	10 MAX	1 MIN	2	3,5	5 MED	7,5	10 MAX
Air flow	m ³ /h	75	90	110	130	170	205	125	145	175	205	255	305	190	225	270	315	395	470
Cooling total emission	kW	0,40	0,48	0,58	0,66	0,80	0,92	0,67	0,83	1,01	1,15	1,39	1,62	0,92	1,08	1,56	1,91	2,30	2,61
Cooling sensible emission	kW	0,30	0,36	0,44	0,52	0,64	0,75	0,50	0,62	0,76	0,88	1,08	1,28	0,67	0,79	1,15	1,41	1,72	1,99
Heating emission	kW	0,55	0,60	0,68	0,78	0,96	1,10	0,97	1,01	1,16	1,32	1,57	1,81	1,52	1,62	1,85	2,10	2,53	2,90
Dp Cooling	kPa	4,9	6,0	7,5	9,1	12,0	14,7	3,1	3,6	4,3	4,9	6,1	7,4	4,5	5,4	8,6	11,5	15,2	18,6
Dp Heating	kPa	6,1	6,7	8,0	9,6	13,0	16,2	3,7	3,9	4,4	5,0	6,1	7,3	7,1	7,7	9,2	11,0	14,6	18,2
Motor power input	W	3,2	3,5	4,2	5,2	7,4	10,3	3,7	4,0	4,9	6,3	9,5	14,0	4,1	4,8	6,3	8,6	14,1	21,6
Sound power (Lw)	dB(A)	31	33	36	40	45	50	30	33	38	42	47	52	32	34	39	43	47	53
Sound pressure (Lp) ⁽¹⁾	dB(A)	22	24	27	31	36	41	21	24	29	33	38	43	23	25	30	34	38	44

MODEL	Inverter power	CFF-ECM 40						CFF-ECM 50					
		1 MIN	2	3,5	5 MED	7,5	10 MAX	1 MIN	2	3,5	5 MED	7,5	10 MAX
Air flow	m ³ /h	220	260	320	380	480	575	255	300	365	430	535	645
Cooling total emission	kW	1,14	1,45	2,06	2,50	2,97	3,36	1,44	1,95	2,55	2,92	3,37	3,81
Cooling sensible emission	kW	0,67	0,79	1,15	1,41	1,72	1,99	1,04	1,40	1,82	2,10	2,47	2,83
Heating emission	kW	1,79	1,91	2,23	2,58	3,13	3,62	2,19	2,25	2,61	3,00	3,60	4,20
Dp Cooling	kPa	7,3	10,2	17,3	23,7	31,7	39,1	4,6	6,4	9,1	11,2	13,9	16,9
Dp Heating	kPa	11,7	12,9	16,3	20,6	28,3	36,2	6,4	6,6	8,0	9,7	12,8	16,2
Motor power input	W	4,7	5,4	7,2	9,9	16,4	25,4	5,3	6,1	8,2	11,4	19,0	29,5
Sound power (Lw)	dB(A)	33	37	41	45	51	55	34	38	42	46	51	55
Sound pressure (Lp) ⁽¹⁾	dB(A)	24	28	32	36	42	46	25	29	33	37	42	46

(1) The sound pressure levels are 9 dB (A) lower than the sound power levels, apply to the reverberant field of a 100 m³ room and a reverberation time of 0.5 sec.

COOLING EMISSION

Entering air temperature: 27 °C – R.H.: 50%

Model	Vdc	WT: 7 / 12 °C					WT: 8 / 13 °C					WT: 10 / 15 °C				WT: 12 / 17 °C			
		Qv m³/h	Pc kW	Ps kW	Qw l/h	Dp(c) kPa	Pc kW	Ps kW	Qw l/h	Dp(c) kPa	Pc kW	Ps kW	Qw l/h	Dp(c) kPa	Pc kW	Ps kW	Qw l/h	Dp(c) kPa	
CFF-ECM 10	10	205	0,99	0,73	172	16,6	0,88	0,70	154	13,9	0,69	0,66	120	9,6	0,53	0,53	93	6,7	
	7,5	170	0,87	0,63	151	13,5	0,78	0,60	135	11,4	0,60	0,56	105	7,9	0,46	0,46	80	5,6	
	5	130	0,72	0,51	124	10,1	0,64	0,48	111	8,6	0,50	0,45	86	6,2	0,38	0,38	65	4,5	
	3,5	110	0,63	0,44	108	8,3	0,56	0,42	97	7,2	0,43	0,38	75	5,2	0,33	0,33	57	3,9	
	2	90	0,52	0,36	90	6,6	0,47	0,34	81	5,8	0,36	0,31	63	4,3	0,27	0,27	47	3,4	
	1	75	0,44	0,30	75	5,3	0,39	0,28	68	4,7	0,30	0,26	53	3,7	0,23	0,23	40	3,0	
CFF-ECM 20	10	305	1,76	1,26	306	8,3	1,57	1,20	273	7,1	1,21	1,09	211	5,2	0,91	0,91	160	3,9	
	7,5	255	1,51	1,06	261	6,7	1,34	1,01	233	5,8	1,04	0,92	180	4,4	0,78	0,78	136	3,4	
	5	205	1,24	0,87	215	5,3	1,11	0,82	192	4,7	0,86	0,75	149	3,7	0,64	0,64	112	3,0	
	3,5	175	1,09	0,75	188	4,6	0,97	0,71	169	4,1	0,75	0,64	130	3,3	0,56	0,56	97	2,8	
	2	145	0,90	0,62	155	3,8	0,81	0,58	139	3,5	0,62	0,53	107	2,9	0,46	0,46	80	2,6	
	1	125	0,72	0,50	124	3,2	0,65	0,47	112	3,0	0,50	0,43	87	2,6	0,38	0,38	66	2,4	
CFF-ECM 30	10	470	2,81	1,97	488	21,0	2,53	1,86	438	17,6	1,96	1,70	341	11,9	1,48	1,48	259	7,9	
	7,5	395	2,47	1,71	428	17,1	2,23	1,61	385	14,4	1,73	1,46	300	9,8	1,30	1,30	226	6,7	
	5	315	2,05	1,40	355	12,7	1,86	1,32	321	10,9	1,44	1,19	248	7,6	1,07	1,07	186	5,3	
	3,5	270	1,68	1,14	290	9,5	1,51	1,08	262	8,2	1,18	0,97	204	5,9	0,89	0,89	153	4,3	
	2	225	1,16	0,79	201	5,8	1,05	0,75	181	5,2	0,82	0,68	142	4,0	0,63	0,63	109	3,2	
	1	190	0,99	0,67	171	4,9	0,89	0,63	154	4,4	0,70	0,57	121	3,5	0,53	0,53	92	2,9	
CFF-ECM 40	10	575	3,60	2,47	624	44,1	3,26	2,33	565	37,0	2,54	2,12	441	24,2	1,91	1,91	333	15,3	
	7,5	480	3,18	2,16	550	35,6	2,88	2,03	498	29,9	2,24	1,83	388	19,7	1,68	1,66	292	12,5	
	5	380	2,68	1,79	462	26,5	2,43	1,69	419	22,5	1,89	1,51	327	14,9	1,41	1,36	244	9,6	
	3,5	320	2,21	1,47	381	19,3	2,00	1,39	346	16,5	1,56	1,24	270	11,2	1,17	1,12	202	7,4	
	2	260	1,56	1,04	269	11,2	1,41	0,98	244	9,7	1,11	0,88	191	6,9	0,84	0,82	145	5,0	
	1	220	1,22	0,82	211	8,0	1,11	0,77	191	7,0	0,87	0,69	150	5,2	0,66	0,66	115	3,9	
CFF-ECM 50	10	645	4,10	2,81	710	18,9	3,70	2,65	641	16,0	2,87	2,40	498	10,8	2,15	2,15	376	7,3	
	7,5	535	3,62	2,46	626	15,5	3,28	2,31	567	13,2	2,53	2,07	439	9,0	1,89	1,87	329	6,1	
	5	430	3,14	2,10	541	12,4	2,84	1,98	491	10,7	2,20	1,75	380	7,4	1,64	1,57	283	5,2	
	3,5	365	2,72	1,81	470	10,0	2,47	1,71	427	8,7	1,92	1,51	331	6,2	1,42	1,34	246	4,5	
	2	300	2,09	1,40	361	7,0	1,90	1,31	328	6,2	1,48	1,17	255	4,6	1,10	1,06	190	3,5	
	1	255	1,55	1,04	267	4,9	1,40	0,98	242	4,4	1,10	0,88	190	3,6	0,83	0,83	144	2,9	

WT: Water temperature
Vdc: Inverter power
Qv: Air flow
Pc: Cooling total emission
Ps: Cooling sensible emission
Qw: Water flow rate
Dp(c): Dp Cooling

Entering air temperature 26 °C – R.H.: 50%

Model	Vdc	WT: 7 / 12 °C					WT: 8 / 13 °C					WT: 10 / 15 °C					WT: 12 / 17 °C				
		Qv m ³ /h	Pc kW	Ps kW	Qw l/h	Dp(c) kPa	Pc kW	Ps kW	Qw l/h	Dp(c) kPa	Pc kW	Ps kW	Qw l/h	Dp(c) kPa	Pc kW	Ps kW	Qw l/h	Dp(c) kPa			
CFF-ECM 10	10	205	0,88	0,70	153	13,8	0,78	0,68	136	11,5	0,61	0,61	106	8,0	0,46	0,46	81	5,7			
	7,5	170	0,77	0,60	134	11,3	0,68	0,58	119	9,5	0,53	0,53	92	6,7	0,40	0,40	70	4,8			
	5	130	0,64	0,48	111	8,6	0,57	0,46	98	7,3	0,43	0,43	75	5,3	0,33	0,33	57	3,9			
	3,5	110	0,56	0,42	97	7,2	0,49	0,40	85	6,1	0,38	0,37	66	4,5	0,28	0,28	49	3,5			
	2	90	0,47	0,34	81	5,7	0,41	0,33	71	5,0	0,31	0,30	55	3,8	0,23	0,23	41	3,1			
	1	75	0,39	0,28	67	4,7	0,34	0,27	60	4,2	0,26	0,25	46	3,3	0,20	0,20	34	2,8			
CFF-ECM 20	10	305	1,56	1,20	271	7,1	1,38	1,15	240	6,1	1,06	1,04	184	4,5	0,79	0,79	138	3,5			
	7,5	255	1,34	1,01	231	5,8	1,18	0,96	205	5,0	0,90	0,88	157	3,9	0,67	0,67	117	3,1			
	5	205	1,11	0,82	191	4,7	0,98	0,78	169	4,2	0,74	0,71	129	3,3	0,55	0,55	96	2,8			
	3,5	175	0,97	0,71	168	4,1	0,86	0,68	148	3,7	0,65	0,61	113	3,0	0,48	0,48	84	2,6			
	2	145	0,80	0,58	138	3,5	0,71	0,55	122	3,2	0,54	0,50	93	2,7	0,40	0,40	69	2,4			
	1	125	0,64	0,47	111	3,0	0,57	0,44	99	2,8	0,44	0,41	76	2,5	0,33	0,33	57	2,3			
CFF-ECM 30	10	470	2,51	1,87	436	17,6	2,23	1,78	387	14,5	1,71	1,62	298	9,8	1,28	1,28	224	6,6			
	7,5	395	2,22	1,62	384	14,4	1,96	1,54	340	11,9	1,50	1,39	261	8,1	1,12	1,12	195	5,6			
	5	315	1,84	1,32	318	10,8	1,63	1,25	283	9,1	1,25	1,13	216	6,3	0,93	0,93	161	4,5			
	3,5	270	1,50	1,08	260	8,1	1,34	1,02	231	6,9	1,02	0,93	177	5,0	0,76	0,76	132	3,8			
	2	225	1,04	0,75	180	5,2	0,93	0,70	160	4,6	0,72	0,66	124	3,6	0,55	0,55	95	3,0			
	1	190	0,88	0,63	153	4,4	0,79	0,59	136	3,9	0,61	0,56	106	3,2	0,46	0,46	80	2,7			
CFF-ECM 40	10	575	3,24	2,34	561	36,7	2,88	2,22	499	30,0	2,21	2,02	384	19,3	1,65	1,65	289	12,3			
	7,5	480	2,86	2,04	495	29,7	2,54	1,93	441	24,4	1,95	1,74	338	15,7	1,45	1,45	252	10,0			
	5	380	2,41	1,69	416	22,3	2,15	1,60	371	18,4	1,64	1,43	283	12,0	1,21	1,21	210	7,8			
	3,5	320	1,99	1,39	343	16,3	1,78	1,31	307	13,7	1,36	1,18	234	9,1	1,00	1,00	174	6,1			
	2	260	1,40	0,99	242	9,6	1,25	0,92	217	8,2	0,96	0,85	167	5,9	0,72	0,72	125	4,3			
	1	220	1,10	0,77	190	6,9	0,98	0,72	170	6,0	0,76	0,67	131	4,5	0,57	0,57	99	3,5			
CFF-ECM 50	10	645	3,68	2,66	637	15,9	3,26	2,52	566	13,2	2,49	2,29	434	8,9	1,86	1,86	324	6,0			
	7,5	535	3,25	2,32	563	13,1	2,88	2,19	499	10,9	2,20	1,97	382	7,5	1,63	1,63	284	5,2			
	5	430	2,82	1,98	487	10,6	2,50	1,87	433	8,9	1,91	1,65	330	6,2	1,40	1,40	243	4,4			
	3,5	365	2,45	1,71	424	8,7	2,18	1,61	377	7,4	1,66	1,42	287	5,3	1,22	1,22	211	3,9			
	2	300	1,88	1,32	325	6,1	1,68	1,24	291	5,4	1,28	1,11	221	4,0	0,94	0,94	164	3,2			
	1	255	1,39	0,98	240	4,4	1,24	0,92	215	4,0	0,96	0,85	165	3,2	0,72	0,72	124	2,7			

WT: Water temperature
Vdc: Inverter power
Qv: Air flow
Pc: Cooling total emission
Ps: Cooling sensible emission
Qw: Water flow rate
Dp(c): Dp Cooling

Entering air temperature: 25 °C – R.H.: 50%

Model	Vdc	WT: 7 / 12 °C					WT: 8 / 13 °C					WT: 10 / 15 °C				WT: 12 / 17 °C			
		Qv m ³ /h	Pc kW	Ps kW	Qw l/h	Dp(c) kPa	Pc kW	Ps kW	Qw l/h	Dp(c) kPa	Pc kW	Ps kW	Qw l/h	Dp(c) kPa	Pc kW	Ps kW	Qw l/h	Dp(c) kPa	
CFF-ECM 10	10	205	0,78	0,68	136	11,5	0,69	0,65	120	9,6	0,53	0,53	93	6,7	0,45	0,45	79	5,5	
	7,5	170	0,68	0,58	119	9,5	0,60	0,56	105	8,0	0,46	0,46	81	5,7	0,39	0,39	68	4,7	
	5	130	0,56	0,46	98	7,3	0,50	0,44	86	6,2	0,38	0,38	66	4,5	0,30	0,30	52	3,6	
	3,5	110	0,49	0,40	85	6,1	0,43	0,38	75	5,2	0,33	0,33	57	4,0	0,25	0,25	43	3,2	
	2	90	0,41	0,33	71	5,0	0,36	0,31	62	4,3	0,27	0,27	48	3,4	0,20	0,20	35	2,8	
	1	75	0,34	0,27	59	4,1	0,30	0,26	52	3,7	0,23	0,23	40	3,0	0,17	0,17	30	2,6	
CFF-ECM 20	10	305	1,38	1,14	239	6,0	1,21	1,09	211	5,2	0,92	0,92	160	3,9	0,77	0,77	134	3,4	
	7,5	255	1,18	0,96	204	5,0	1,03	0,92	180	4,4	0,78	0,78	136	3,5	0,62	0,62	109	3,0	
	5	205	0,97	0,78	168	4,2	0,86	0,74	148	3,7	0,65	0,65	112	3,0	0,49	0,49	85	2,6	
	3,5	175	0,85	0,68	147	3,7	0,75	0,64	129	3,3	0,56	0,56	98	2,8	0,42	0,42	72	2,5	
	2	145	0,70	0,55	122	3,2	0,62	0,53	107	2,9	0,47	0,47	81	2,6	0,34	0,34	60	2,3	
	1	125	0,57	0,44	98	2,8	0,50	0,42	86	2,6	0,38	0,38	66	2,4	0,28	0,28	49	2,2	
CFF-ECM 30	10	470	2,22	1,78	386	14,5	1,96	1,69	340	11,9	1,49	1,49	260	8,0	1,11	1,11	194	5,5	
	7,5	395	1,95	1,54	339	11,9	1,72	1,46	298	9,8	1,30	1,30	227	6,7	0,97	0,97	169	4,8	
	5	315	1,63	1,26	281	9,1	1,43	1,19	247	7,6	1,08	1,08	187	5,3	0,80	0,80	139	3,9	
	3,5	270	1,33	1,02	230	6,9	1,17	0,97	203	5,9	0,89	0,89	154	4,3	0,66	0,66	114	3,4	
	2	225	0,92	0,70	159	4,5	0,82	0,68	141	4,0	0,63	0,63	109	3,3	0,47	0,47	82	2,8	
	1	190	0,78	0,59	136	3,9	0,69	0,57	120	3,5	0,53	0,53	92	2,9	0,40	0,40	70	2,6	
CFF-ECM 40	10	575	2,86	2,22	497	29,9	2,53	2,11	439	24,2	1,92	1,92	334	15,5	1,43	1,43	249	9,9	
	7,5	480	2,54	1,94	439	24,3	2,23	1,83	387	19,7	1,69	1,65	293	12,6	1,25	1,25	217	8,2	
	5	380	2,14	1,60	370	18,4	1,88	1,51	325	14,9	1,42	1,35	245	9,7	1,04	1,04	180	6,4	
	3,5	320	1,77	1,31	305	13,6	1,55	1,24	268	11,2	1,17	1,12	203	7,5	0,86	0,86	149	5,1	
	2	260	1,25	0,93	215	8,2	1,10	0,88	190	6,9	0,84	0,82	145	5,0	0,63	0,63	109	3,8	
	1	220	0,98	0,73	169	6,0	0,86	0,69	149	5,2	0,66	0,65	115	4,0	0,50	0,50	86	3,2	
CFF-ECM 50	10	645	3,25	2,53	564	13,2	2,86	2,40	496	10,8	2,16	2,16	377	7,3	1,60	1,60	280	5,1	
	7,5	535	2,87	2,20	497	10,9	2,52	2,08	437	9,0	1,90	1,87	330	6,2	1,40	1,40	244	4,4	
	5	430	2,49	1,87	431	8,9	2,19	1,76	379	7,4	1,64	1,56	284	5,2	1,20	1,20	208	3,8	
	3,5	365	2,17	1,61	375	7,4	1,91	1,51	329	6,2	1,43	1,34	247	4,5	1,04	1,04	180	3,4	
	2	300	1,67	1,24	289	5,4	1,47	1,17	254	4,6	1,10	1,05	191	3,6	0,81	0,81	140	2,9	
	1	255	1,24	0,92	214	3,9	1,09	0,88	189	3,5	0,83	0,82	144	2,9	0,62	0,62	108	2,6	

- WT:** Water temperature
- Vdc:** Inverter power
- Qv:** Air flow
- Pc:** Cooling total emission
- Ps:** Cooling sensible emission
- Qw:** Water flow rate
- Dp(c):** Dp Cooling

HEATING EMISSION

Entering air temperature: 18 °C

Model	Vdc	WT: 70 / 60 °C				WT: 60 / 50 °C			WT: 50 / 40 °C			WT: 50 / 45 °C			WT: 45 / 40 °C		
		Qv m ³ /h	Ph kW	Qw l/h	Dp(h) kPa	Ph kW	Qw l/h	Dp(h) kPa	Ph kW	Qw l/h	Dp(h) kPa	Ph kW	Qw l/h	Dp(h) kPa	Ph kW	Qw l/h	Dp(h) kPa
CFF-ECM 10	10	205	2,35	202	16,7	1,83	157	11,7	1,31	113	7,5	1,47	252	25,3	1,21	208	18,8
	7,5	170	2,03	175	13,3	1,59	136	9,5	1,14	98	6,3	1,27	218	19,9	1,05	180	14,9
	5	130	1,66	142	9,8	1,30	111	7,2	0,93	80	5,0	1,03	178	14,4	0,86	147	11,0
	3,5	110	1,45	125	8,1	1,14	98	6,1	0,82	71	4,4	0,90	155	11,7	0,75	129	9,1
	2	90	1,26	108	6,8	0,99	85	5,2	0,72	62	3,9	0,79	135	9,6	0,65	112	7,5
CFF-ECM 20	1	75	1,17	101	6,2	0,92	79	4,8	0,67	57	3,6	0,73	126	8,6	0,61	104	6,8
	10	305	3,84	330	7,5	3,00	258	5,6	2,16	186	4,1	2,40	412	10,6	1,98	341	8,3
	7,5	255	3,33	287	6,2	2,61	225	4,8	1,88	162	3,6	2,08	358	8,7	1,72	296	6,8
	5	205	2,79	240	5,1	2,19	188	4,1	1,59	136	3,2	1,74	299	6,9	1,44	248	5,5
	3,5	175	2,45	211	4,4	1,93	166	3,6	1,40	120	2,9	1,53	263	5,8	1,27	218	4,8
CFF-ECM 30	2	145	2,15	185	3,9	1,69	145	3,3	1,23	106	2,7	1,34	230	5,0	1,11	191	4,2
	1	125	2,05	176	3,8	1,61	139	3,2	1,17	101	2,7	1,27	219	4,8	1,06	182	4,0
	10	470	6,14	528	18,6	4,83	415	13,1	3,50	301	8,5	3,83	659	28,2	3,18	547	21,1
	7,5	395	5,34	459	14,9	4,20	362	10,7	3,06	263	7,1	3,33	572	22,3	2,76	475	16,8
	5	315	4,44	382	11,2	3,50	301	8,2	2,55	220	5,7	2,76	475	16,5	2,30	395	12,6
CFF-ECM 40	3,5	270	3,90	336	9,3	3,08	265	6,9	2,25	194	4,9	2,43	417	13,5	2,02	347	10,4
	2	225	3,42	295	7,8	2,71	233	5,9	1,98	171	4,3	2,13	366	11,1	1,77	305	8,7
	1	190	3,21	276	7,1	2,54	218	5,5	1,86	160	4,1	1,99	343	10,1	1,66	286	7,9
	10	575	7,64	657	36,8	6,02	518	25,4	4,39	378	15,8	4,76	819	56,9	3,95	680	42,1
	7,5	480	6,60	567	28,7	5,21	448	20,1	3,81	328	12,7	4,11	707	44,1	3,42	588	32,8
CFF-ECM 50	5	380	5,44	468	20,9	4,30	370	14,8	3,15	271	9,6	3,38	582	31,7	2,82	485	23,8
	3,5	320	4,70	405	16,5	3,72	320	11,9	2,74	235	7,9	2,92	503	24,8	2,44	419	18,8
	2	260	4,04	347	13,0	3,20	275	9,5	2,36	203	6,5	2,51	431	19,3	2,09	360	14,7
	1	220	3,78	325	11,8	3,00	258	8,7	2,21	190	6,0	2,35	404	17,4	1,96	337	13,3
	10	645	8,87	763	16,5	6,99	601	11,8	5,10	439	7,7	5,52	950	24,9	4,59	790	18,7
CFF-ECM 50	7,5	535	7,60	654	13,0	6,00	516	9,4	4,39	377	6,4	4,73	814	19,3	3,94	677	14,7
	5	430	6,32	544	9,9	5,00	430	7,3	3,67	315	5,2	3,93	676	14,4	3,28	563	11,1
	3,5	365	5,49	472	8,1	4,35	374	6,2	3,20	275	4,5	3,41	587	11,6	2,85	489	9,1
	2	300	4,75	409	6,7	3,77	324	5,2	2,78	239	3,9	2,95	507	9,4	2,46	423	7,4
	1	255	4,62	397	6,5	3,67	315	5,1	2,70	232	3,8	2,87	493	9,0	2,39	412	7,2

WT: Water temperature
Vdc: Inverter power
Qv: Air flow
Ph: Heating emission
Qw: Water flow rate
Dp(h): Dp Heating

Entering air temperature: 20 °C

Model	Vdc	WT: 70 / 60 °C				WT: 60 / 50 °C			WT: 50 / 45 °C			WT: 50 / 40 °C			WT: 45 / 40 °C		
		Qv m ³ /h	Ph kW	Qw l/h	Dp(h) kPa	Ph kW	Qw l/h	Dp(h) kPa	Ph kW	Qw l/h	Dp(h) kPa	Ph kW	Qw l/h	Dp(h) kPa	Ph kW	Qw l/h	Dp(h) kPa
CFF-ECM 10	10	205	2,23	192	15,4	1,72	148	10,7	1,20	103	6,7	1,36	234	22,3	1,10	190	16,2
	7,5	170	1,93	166	12,3	1,49	128	8,7	1,04	90	5,7	1,18	202	17,6	0,96	165	13,0
	5	130	1,58	136	9,2	1,22	105	6,7	0,86	74	4,6	0,96	165	12,8	0,78	134	9,6
	3,5	110	1,38	119	7,6	1,07	92	5,7	0,75	65	4,0	0,84	144	10,5	0,68	118	8,0
	2	90	1,20	103	6,4	0,93	80	4,9	0,66	57	3,6	0,73	125	8,6	0,60	102	6,7
	1	75	1,12	96	5,8	0,87	74	4,5	0,61	53	3,4	0,68	116	7,8	0,55	95	6,1
CFF-ECM 20	10	305	3,66	315	7,0	2,82	243	5,2	1,98	170	3,8	2,22	382	9,5	1,81	311	7,3
	7,5	255	3,18	273	5,9	2,46	211	4,5	1,73	149	3,4	1,93	332	7,8	1,57	270	6,1
	5	205	2,66	229	4,8	2,06	177	3,8	1,46	125	3,0	1,61	278	6,2	1,32	227	5,0
	3,5	175	2,34	201	4,2	1,81	156	3,5	1,29	111	2,8	1,42	244	5,3	1,16	199	4,4
	2	145	2,05	176	3,8	1,59	137	3,2	1,13	97	2,6	1,24	213	4,6	1,01	174	3,9
	1	125	1,95	168	3,6	1,52	130	3,1	1,08	93	2,6	1,18	203	4,4	0,97	166	3,7
CFF-ECM 30	10	470	5,85	503	17,2	4,54	391	12,0	3,23	277	7,6	3,55	611	24,9	2,90	499	18,2
	7,5	395	5,09	438	13,8	3,96	340	9,8	2,82	242	6,4	3,09	531	19,8	2,53	434	14,6
	5	315	4,23	364	10,5	3,30	283	7,6	2,35	202	5,2	2,56	441	14,7	2,10	361	11,0
	3,5	270	3,72	320	8,7	2,90	249	6,4	2,08	179	4,5	2,25	387	12,1	1,85	318	9,2
	2	225	3,26	281	7,3	2,55	219	5,5	1,83	157	4,0	1,98	340	10,0	1,62	279	7,7
	1	190	3,06	263	6,7	2,39	206	5,1	1,72	148	3,8	1,85	318	9,1	1,52	261	7,1
CFF-ECM 40	10	575	7,27	626	33,8	5,67	487	23,0	4,05	348	13,9	4,42	759	50,0	3,62	622	36,2
	7,5	480	6,29	541	26,5	4,90	422	18,2	3,51	302	11,2	3,81	656	38,9	3,13	538	28,3
	5	380	5,18	446	19,3	4,05	348	13,5	2,91	250	8,6	3,14	540	28,0	2,58	443	20,6
	3,5	320	4,48	386	15,3	3,51	302	10,9	2,52	217	7,1	2,71	467	22,0	2,23	384	16,3
	2	260	3,85	331	12,1	3,02	259	8,8	2,18	187	5,9	2,33	400	17,2	1,91	329	12,9
	1	220	3,61	310	11,0	2,83	243	8,0	2,04	176	5,5	2,18	375	15,5	1,79	309	11,7
CFF-ECM 50	10	645	8,45	727	15,3	6,58	566	10,8	4,70	404	7,0	5,12	881	22,0	4,20	722	16,2
	7,5	535	7,24	623	12,1	5,65	486	8,7	4,04	348	5,8	4,39	755	17,1	3,60	619	12,8
	5	430	6,03	518	9,2	4,71	405	6,8	3,38	291	4,7	3,65	628	12,8	3,00	515	9,7
	3,5	365	5,24	450	7,6	4,10	352	5,7	2,95	254	4,1	3,17	545	10,4	2,61	448	8,0
	2	300	4,53	390	6,3	3,55	305	4,9	2,56	220	3,7	2,74	471	8,5	2,25	388	6,6
	1	255	4,40	379	6,1	3,45	297	4,7	2,49	214	3,6	2,66	458	8,2	2,19	377	6,4

WT: Water temperature
Vdc: Inverter power
Qv: Air flow
Ph: Heating emission
Qw: Water flow rate
Dp(h): Dp Heating

Entering air temperature: 22 °C

Model	Vdc	WT: 70 / 60 °C			WT: 60 / 50 °C			WT: 50 / 40 °C			WT: 50 / 45 °C			WT: 45 / 40 °C			
		Qv m ³ /h	Ph kW	Qw l/h	Dp(h) kPa	Ph kW	Qw l/h	Dp(h) kPa	Ph kW	Qw l/h	Dp(h) kPa	Ph kW	Qw l/h	Dp(h) kPa	Ph kW	Qw l/h	Dp(h) kPa
CFF-ECM 10	10	205	2,12	183	14,2	1,61	139	9,7	1,09	94	6,0	1,25	216	19,5	1,00	172	13,9
	7,5	170	1,84	158	11,4	1,40	120	8,0	0,95	82	5,1	1,08	186	15,5	0,87	149	11,2
	5	130	1,50	129	8,5	1,14	98	6,1	0,78	67	4,2	0,88	152	11,3	0,71	122	8,4
	3,5	110	1,31	113	7,1	1,00	86	5,3	0,69	59	3,7	0,77	133	9,3	0,62	106	7,0
	2	90	1,14	98	6,0	0,87	75	4,6	0,60	52	3,4	0,67	116	7,7	0,54	93	5,9
	1	75	1,06	91	5,5	0,81	70	4,2	0,56	48	3,2	0,62	107	7,0	0,50	86	5,4
CFF-ECM 20	10	305	3,48	299	6,6	2,64	227	4,9	1,81	155	3,5	2,05	352	8,5	1,64	282	6,4
	7,5	255	3,02	259	5,5	2,30	198	4,2	1,58	136	3,2	1,78	306	7,0	1,42	245	5,4
	5	205	2,53	217	4,6	1,93	166	3,6	1,33	114	2,9	1,49	256	5,7	1,19	205	4,5
	3,5	175	2,22	191	4,0	1,70	146	3,3	1,17	101	2,7	1,31	225	4,9	1,05	180	4,0
	2	145	1,94	167	3,6	1,49	128	3,0	1,03	89	2,6	1,14	197	4,3	0,92	158	3,6
	1	125	1,85	159	3,5	1,42	122	2,9	0,99	85	2,5	1,09	188	4,1	0,88	151	3,4
CFF-ECM 30	10	470	5,56	478	15,9	4,26	366	10,9	2,95	253	6,7	3,28	564	21,8	2,63	453	15,6
	7,5	395	4,84	416	12,8	3,71	319	8,9	2,58	221	5,7	2,85	490	17,4	2,29	394	12,6
	5	315	4,02	346	9,7	3,09	266	7,0	2,15	185	4,7	2,37	407	13,0	1,91	328	9,6
	3,5	270	3,54	304	8,1	2,72	234	6,0	1,90	163	4,2	2,08	358	10,7	1,68	288	8,0
	2	225	3,11	267	6,9	2,40	206	5,1	1,68	144	3,7	1,83	314	8,9	1,47	253	6,8
	1	190	2,91	250	6,3	2,25	193	4,8	1,57	135	3,5	1,71	294	8,1	1,38	237	6,2
CFF-ECM 40	10	575	6,92	595	31,1	5,32	457	20,8	3,70	319	12,1	4,08	701	43,6	3,28	564	30,6
	7,5	480	5,98	514	24,4	4,60	396	16,5	3,22	277	9,9	3,52	606	33,9	2,84	488	24,0
	5	380	4,93	424	17,8	3,81	327	12,3	2,67	229	7,6	2,90	499	24,5	2,34	403	17,6
	3,5	320	4,27	367	14,2	3,30	283	9,9	2,32	199	6,4	2,51	431	19,3	2,03	348	14,0
	2	260	3,66	315	11,2	2,83	244	8,0	2,00	172	5,3	2,15	370	15,1	1,74	299	11,1
	1	220	3,43	295	10,2	2,66	229	7,4	1,88	161	5,0	2,02	347	13,7	1,63	281	10,1
CFF-ECM 50	10	645	8,04	691	14,1	6,18	531	9,8	4,30	370	6,2	4,73	814	19,3	3,81	655	13,9
	7,5	535	6,89	592	11,2	5,31	456	8,0	3,70	318	5,2	4,05	697	15,1	3,27	562	11,1
	5	430	5,73	493	8,6	4,43	381	6,3	3,10	267	4,3	3,37	580	11,4	2,72	468	8,5
	3,5	365	4,98	428	7,1	3,85	331	5,3	2,70	233	3,8	2,93	504	9,3	2,37	407	7,1
	2	300	4,31	371	6,0	3,34	287	4,6	2,35	202	3,4	2,53	435	7,6	2,05	352	5,9
	1	255	4,19	361	5,8	3,25	279	4,5	2,29	197	3,4	2,46	423	7,3	1,99	343	5,7

WT: Water temperature
Vdc: Inverter power
Qv: Air flow
Ph: Heating emission
Qw: Water flow rate
Dp(h): Dp Heating

WATER SIDE PRESSURE DROP

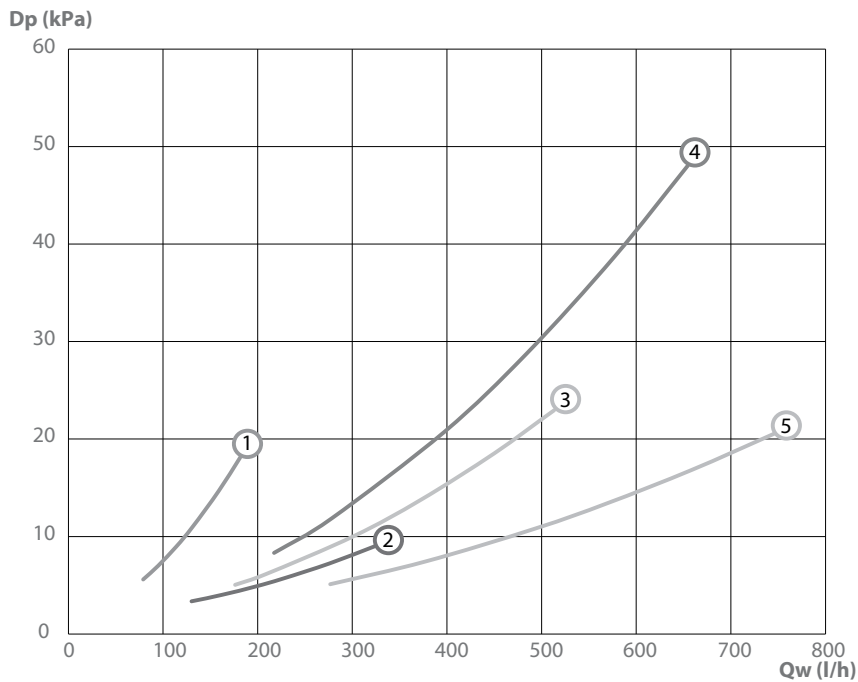

Dp = pressure drop
 Qw = water flow rate
 1 = CFF-ECM 10
 2 = CFF-ECM 20
 3 = CFF-ECM 30
 4 = CFF-ECM 40
 5 = CFF-ECM 50

Pressure drop for mean water temperature of **10 °C**; for different temperatures multiply the pressure drop figure by the **K** correction factors in the table.

	Mean water temperature (°C)						
	20	30	40	50	60	70	80
K correction factor	0,94	0,90	0,86	0,82	0,78	0,74	0,70

OPERATING LIMITS

Description		UoM	Value
Water flow	Highest working pressure	bars	10
		kPa	1000
	Lowest water inlet temperature	°C	6
	Highest water inlet temperature	°C	85
Power supply	Single-phase rated operating voltage	V/Hz	230/50

Coils water flow limits

2 row coil

Model		CFF-ECM 10	CFF-ECM 20	CFF-ECM 30	CFF-ECM 40	CFF-ECM 50
Water flow rate Min.	l/h	40	80		120	
Water flow rate Max.	l/h	200	350	500	600	800

Motor electrical data - max. absorption

Model		CFF-ECM 10	CFF-ECM 20	CFF-ECM 30	CFF-ECM 40	CFF-ECM 50
Motor absorption	W	10,3	14,0	21,6	25,4	29,7
Current absorbed	A	0,155	0,181	0,246	0,286	0,306

DIMENSIONS

Standard version with casing - MV

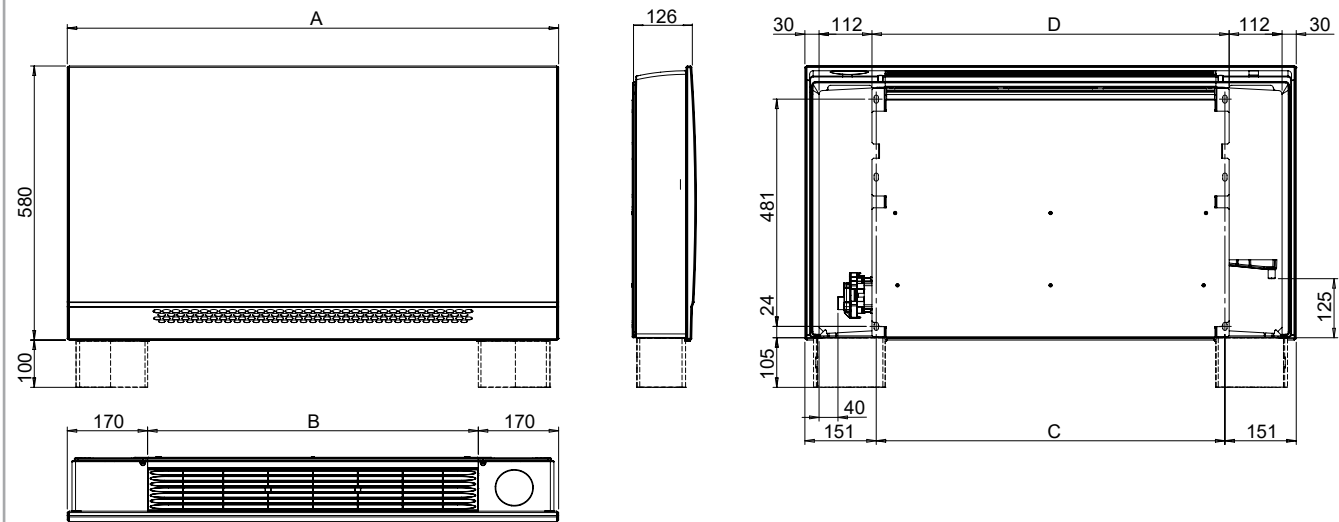

Version for concealed installation - IV

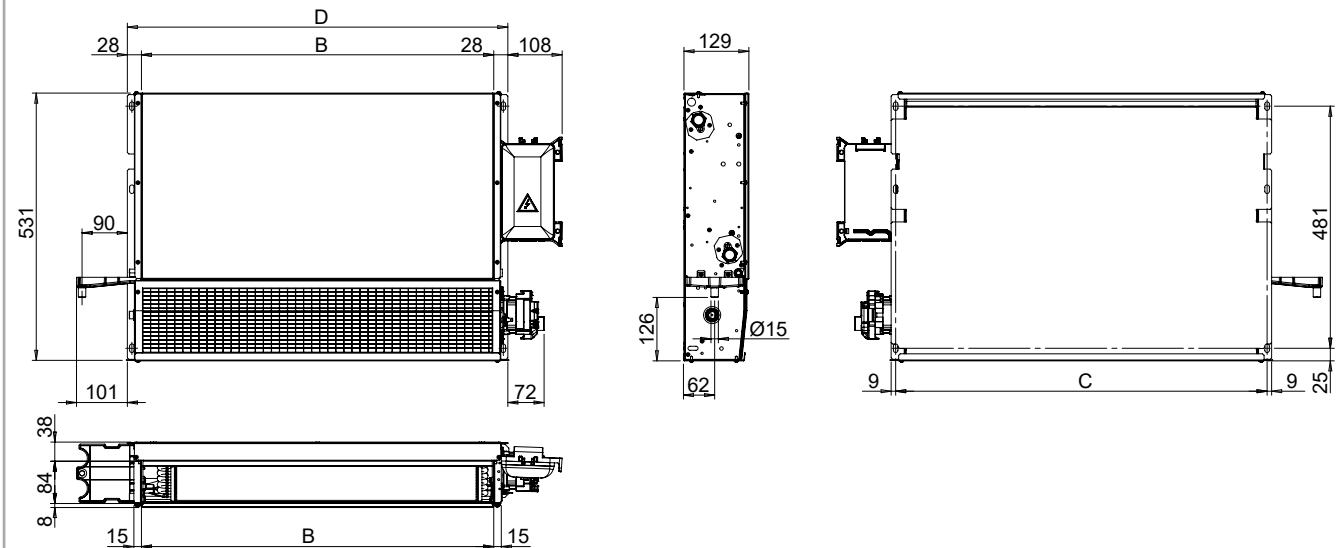

Model		CFF-ECM 10	CFF-ECM 20	CFF-ECM 30	CFF-ECM 40	CFF-ECM 50
A	mm	640	840	1040	1240	1440
B	mm	300	500	700	900	1100
C	mm	338	538	738	938	1138
D	mm	356	556	756	956	1156

Coil connections

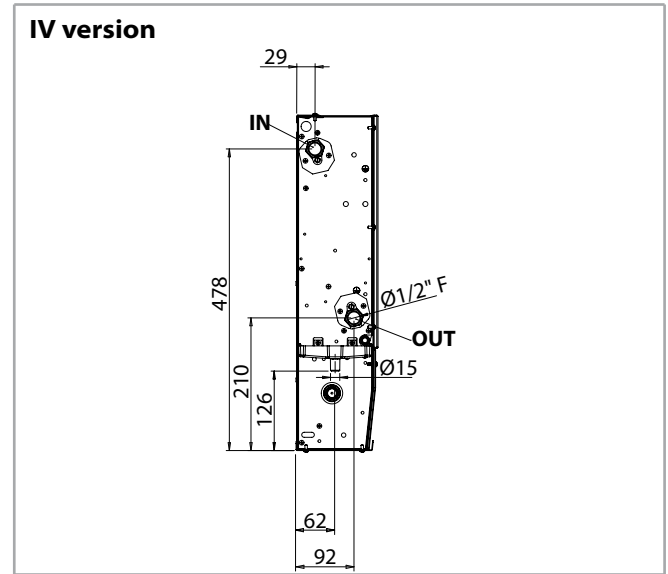
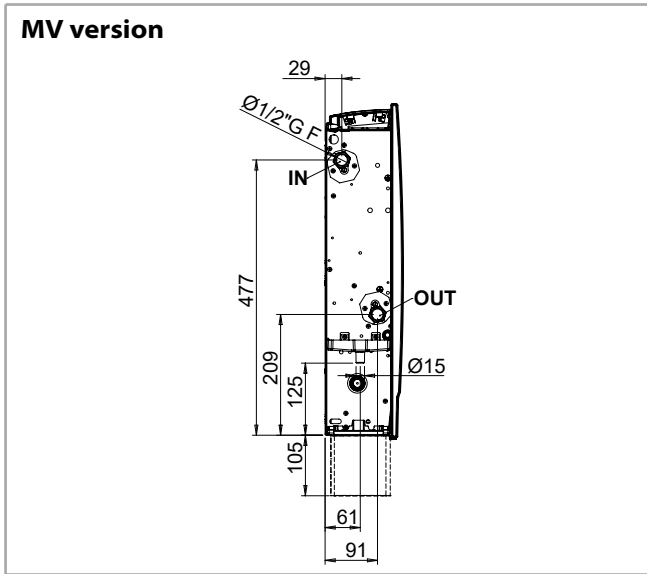

Packed unit

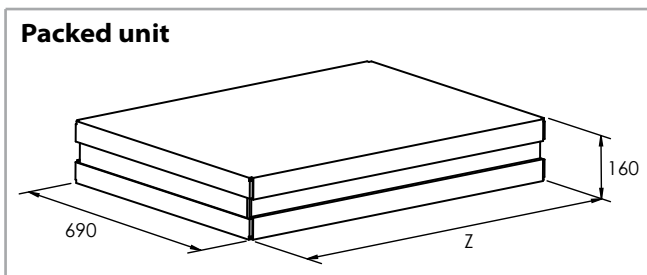

Model	CFF-ECM 10	CFF-ECM 20	CFF-ECM 30	CFF-ECM 40	CFF-ECM 50	
Z	mm	720	920	1120	1320	1520

Weight

The table of the weight is related to the standard versions with casing in the basic configuration without

control and without valves; the weights can change for those units completed with control and/or valve.

Standard version with MV casing

Model		CFF-ECM 10- MV	CFF-ECM 20- MV	CFF-ECM 30- MV	CFF-ECM 40- MV	CFF-ECM 50- MV
Weight with packaging	kg	11,6	14,9	18,5	21,9	25,7
Weight without packaging	kg	10,1	13,2	16,4	19,6	23,0

IV version for concealed installation

Model		CFF-ECM 10- IV	CFF-ECM 20- IV	CFF-ECM 30- IV	CFF-ECM 40- IV	CFF-ECM 50- IV
Weight with packaging	kg	10,1	13,6	17,3	20,9	24,9
Weight without packaging	kg	8,5	11,7	15,1	18,5	22,1

Water content

Model		10	20	30	40	50
Water content	l	0,4	0,7	1,1	1,4	1,7

VALVES

The CFF-ECM units are available either in the versions with mounted valves and in the versions without valves. The features and the installation dimensions of the valves are shown as follows and are valid either for the

versions with mounted valves and for the versions with valves installed on site.

2 way valve

2 way valve ON-OFF 230 V

Model	Kvs m ³ /h	Dp max ⁽¹⁾ kPa	Valve connections (male) Ø	NOT FITTED	
				Code	ID
10-20-30-40-50	1,7	50	1/2"	9071090W	V2-F

(1) Maximum pressure difference for valve to close

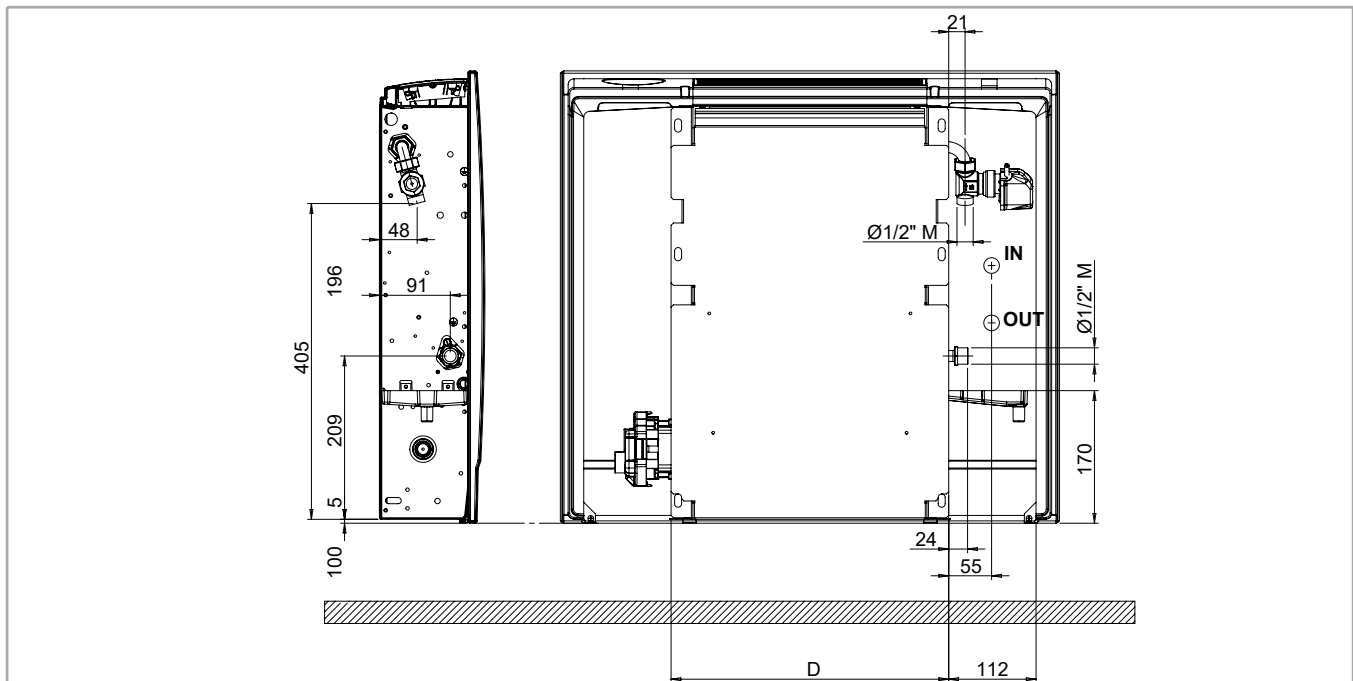

Model	CFF-ECM 10	CFF-ECM 20	CFF-ECM 30	CFF-ECM 40	CFF-ECM 50
D	356	556	756	956	1156

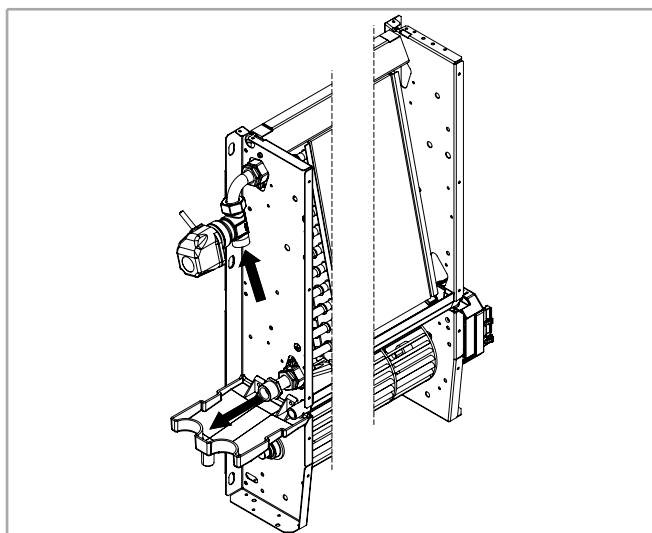

2 way valves pressure drop

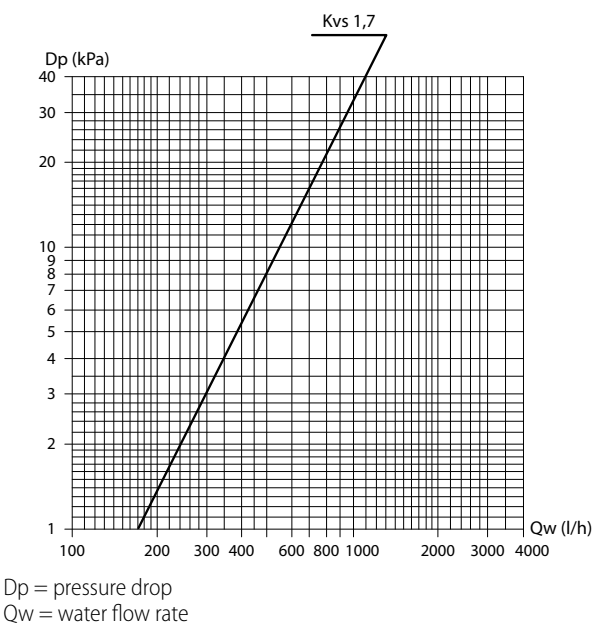

3 way valves

3 way water valve ON-OFF 230 V and mounting kit.

Model	Kvs m ³ /h	Dp max ⁽¹⁾ kPa	Pipe kit connection (male) Ø	NOT FITTED	
				Code	ID
10-20-30-40-50	1,6	50	1/2"	9071091W	V3-F

(1) Maximum pressure difference for valve to close

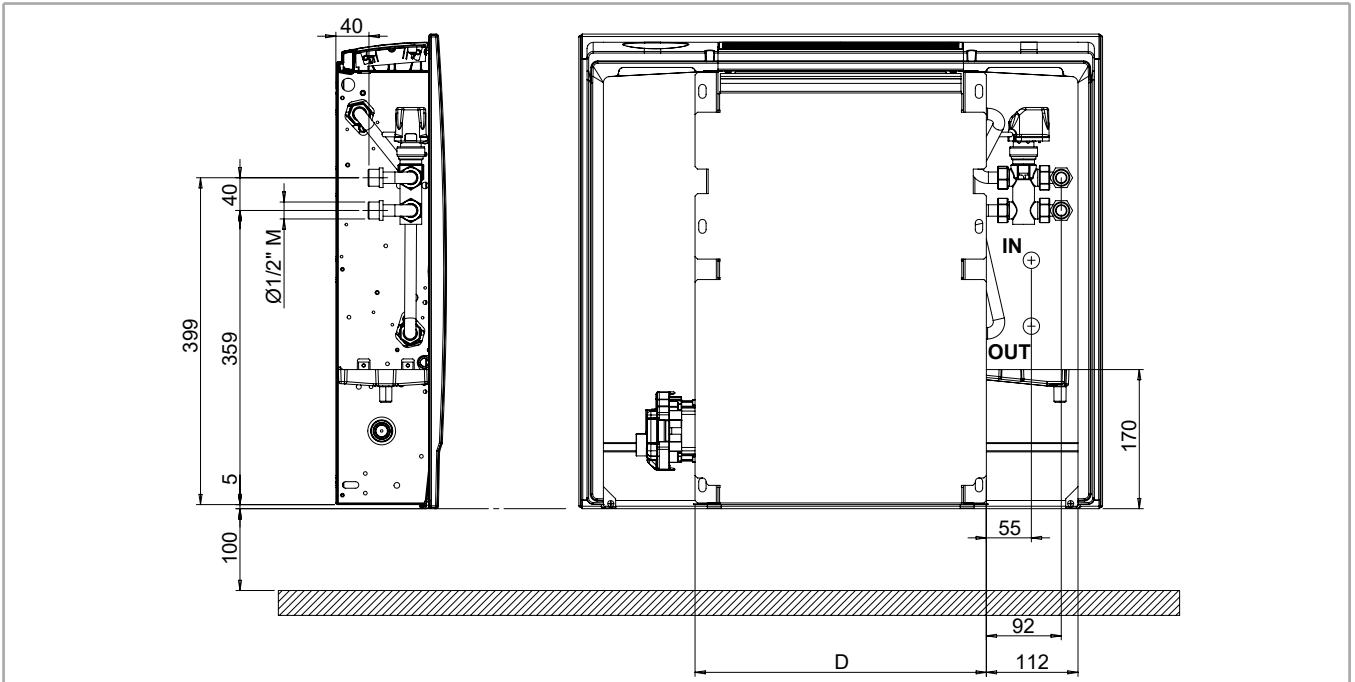

Model	CFF-ECM 10	CFF-ECM 20	CFF-ECM 30	CFF-ECM 40	CFF-ECM 50
D	356	556	756	956	1156

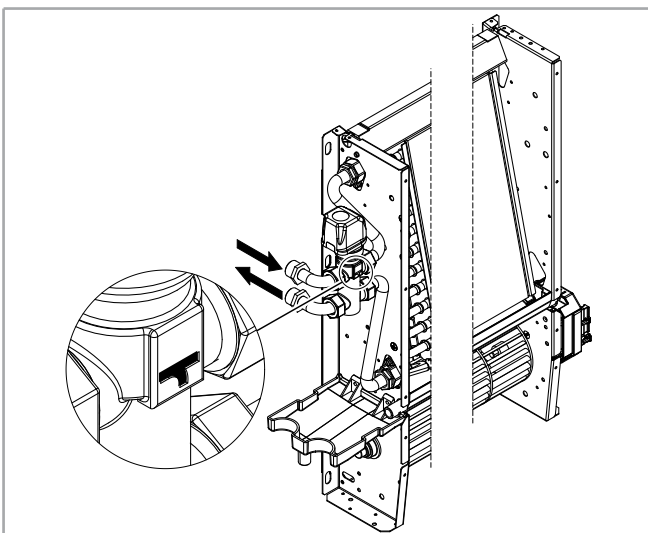

3 way valves pressure drop

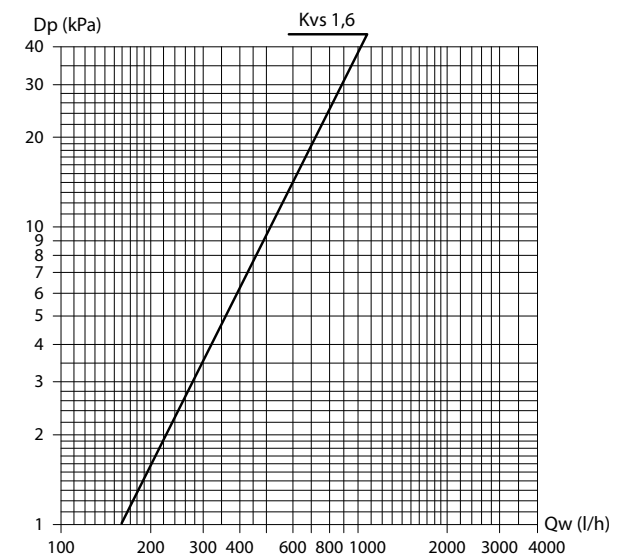

Dp = pressure drop
Qw = water flow rate

CONFIGURATIONS AND ELECTRONIC CONTROLS

Configuration

For this fan coil configuration, the 1-10 Vdc signal, which controls the inverter, must be supplied by a controller with the following signal specifications:

Fan Drive Signal

0 Vdc = Fan OFF

>1 Vdc = Fan ON - Minimum speed

10 Vdc = Maximum speed

Blac-ECM Inverter board

0÷10 Vdc Circuit Input Impedance Value= 100 kOhm

Controls

All the Carisma Whisper CFF-ECM units can be supplied and managed with the following controls:

- **CB-E** control fitted on the unit (only version with casing, available mounted on site or supplied with separate packaging)
- **CB-Touch** control fitted on the unit with Bluetooth and Wi-Fi features (only version with casing; available mounted on site or with separate packaging)
- **WM-AU** wall control (supplied with separate packaging)
- **T-MB** wall control (supplied with separate packaging)

The **CB-Touch** control fitted on the unit allows moreover the control with the **Sabiana Cloud WM** APP. This makes this fan coil unit the ideal solution for the air-conditioning of all residential ambients.

The **CB-Touch** control is equipped with a microprocessor with WiFi feature, that allows to control at distance or remotely all the units installed in your home.

With the WiFi technology you can switch on or off the fan coil units, set the operation mode, the air flux direction and the desired temperature value.

It is moreover possible to manage each single unit or to create some groups; a weekly program can be created by setting, for each day of the week, until four different operation modes.

Just a WiFi connection is required to use the application and to download our **"Sabiana Cloud WM"** APP, that is compatible with the iOS® and Android™ systems.

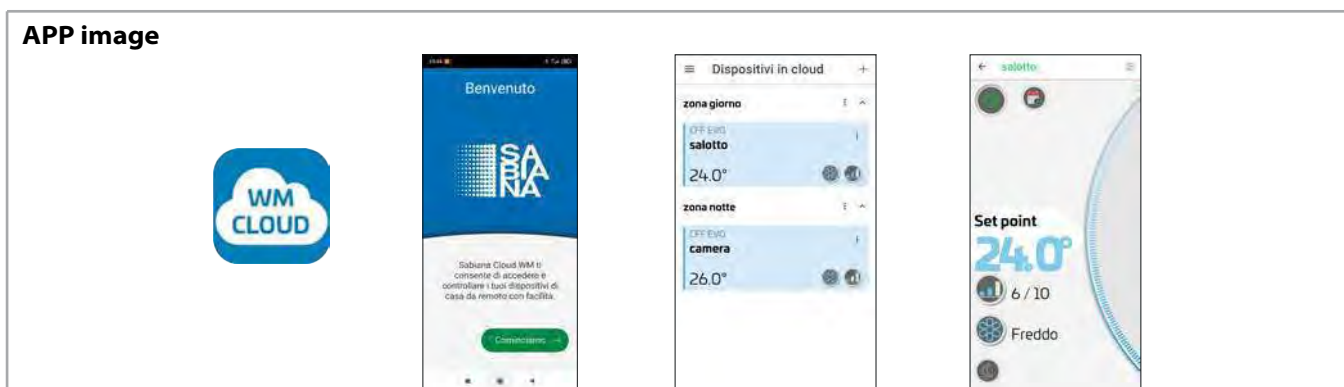

The **CB-E** and **CB-Touch** controls fitted on the unit, whose characteristics are described at p. 22, can be supplied either fitted on the unit or with separate packaging; those controls fitted on the unit that are separately bought can be used only with UP power unit to buy separately.

The **WM-AU** and **T-MB** wall controls, whose characteristics are described from p. 23, are electronic controls that allow to manage one single unit or a group of units (only with the use of a power unit for each unit); the **WM-AU** and **T-MB** controls can be bought only separately and can be used only with **UP-Touch** power units to buy separately.

The room temperature can be controlled through the Sabiana electronic room thermostats and are suitable when the user wants to set the fan speed.

CONTROLS

Controls fitted on the unit features



CB-E control fitted on the unit features

The CB-E control can be used only with a programmable thermostat not supplied by Sabiana. It allows to switch on and off the unit (Stand-by) and therefore to easily set the ventilation by progressively acting on the fan speed, leaving the temperature control to a centralised programmable thermostat or to a thermostat for the home automation system, which, in addition to enabling fan operation, will also control the opening and closing of the water valve on the connection pipe.

After a period of 3 minutes since the last action the brightness of the panel is reduced (SLEEPING mode) in order to increase the energy saving and the comfort during the night; only the symbol  is shown on the display.

By pressing the same button twice, the brightness is restored.



CB-Touch control fitted on the unit features

The CB-Touch control allows to control and adjust the room temperature in a simple and intuitive way by means of a probe positioned in the lower part of the unit.

CB-Touch allows to select the desired operation mode, heat, cool or just ventilate the room, set a desired

temperature set and adjust the fan operating speed according to your needs.

On the one hand the maximum operation speed must be set to reach quickly the comfort temperature. On the other hand the minimum speed must be set when a noiseless operation is required.

With the low temperature cut-out thermostat (T3 sensor collocated between the coil fins; already wired for the units with fitted control, included together with the power unit and to wire for the versions without control) and according to the selected operation there will be as follows:

- winter cycle - the fan will only start operating if the water temperature is above 30°C, thus preventing cold air from flowing out from the unit.
- summer cycle - the fan will only start operating if the water temperature is below 21°C, thus preventing hot air from flowing out from the unit.

To improve comfort, it is also possible to select the night mode which minimises the fan speed and smartly changes the set temperature independently.

The control has a memory, so all settings will not be lost either in the event of switching off or power failure.

After a period of 3 minutes since the last action the brightness of the panel is reduced (SLEEPING mode) in order to increase the energy saving and the comfort during the night; only the symbol  is shown on the display.

By pressing the same button twice, the brightness is restored.



The control is designed to be managed at distance with the smart features of one's own telephone by using the bluetooth wireless connection or wifi via APP downloadable from the Web.

Controls fitted on the unit

CB-E control fitted on the unit

Model	Code	ID
10-20-30-40-50	9071060	CB-E



The control must always be connected with UP-ECO power unit (separately delivered).

(the power unit is already installed on the units with fitted control and must be ordered separately for the versions without control)

The main characteristics are:

- Set the unit ON or stand-by
- Set the fan speed
- Fan OFF and valve closing when the SETPOINT selected with the centralized thermostat (programmable thermostat) is reached.
- Button lock controller
- Regulation of LED brightness

Control power absorption: see the UP-ECO power unit

CB-Touch control fitted on the unit

Model	Code	ID
10-20-30-40-50	9071061	CB-Touch



The control must always be connected with UP-Touch power unit (separately delivered).

(the power unit is already installed on the units with fitted control and must be ordered separately for the versions without control)

The main characteristics are:

- Set the unit ON or stand-by
- Operation mode (Summer/Winter/Ventilation)
- Set the fan speed
- Set the automatic fan speed
- Possibility to use the T1 sensor as return air probe (mounted on the power unit)
- Possibility to use the T3 sensor as low temperature cut-out thermostat (mounted on the power unit)
- It allows to use the T2 sensor as Change-over (mounted on the power unit).
- Night mode
- Alarm messages
- OFFSET regulation
- Button lock controller
- Regulation of LED brightness
- Sabiana Cloud WM application use

Control power absorption: see the UP-Touch power unit

Wall controls

WM-AU wall control

Model	Code	ID
10-20-30-40-50	9066632	WM-AU



The control must always be connected with UP-Touch power unit (separately delivered).

The main characteristics are:

- ON/OFF switch
- Manual/automatic 3 speed switch.
- Manual, automatic or centralized Summer/Winter switch.
- Summer/Winter/Fan/Auto mode push button.
- Electronic room thermostat for fan and water valves control (ON-OFF).
- Simultaneous thermostatic control of the valves and fan.
- Possibility to use the T1 sensor as return air probe (mounted on the power unit)
- Possibility to use the T3 sensor as low temperature cut-out thermostat (mounted on the power unit)
- Possibility to use the T2 sensor as Change-over (mounted on the power unit).
- Energy saving function.
- Presence of a LED signal when the thermostat is on.

Control power absorption: see the UP-Touch power unit

Dimensions: 135x86x24 mm

T-MB wall control

Model	Code	ID
10-20-30-40-50	9066331E	T-MB



The control must always be connected with UP-Touch power unit (separately delivered).

Wall control with display that allows controlling one or more units in Master/Slave mode. The control is equipped with internal sensor to detect the room temperature, which can be defined as a priority compared to the return air sensor on the fan coil.

The main characteristics are:

- ON/OFF switch
- temperature set
- manual, automatic or centralized Summer/Winter switch
- set the fan speed (low, medium, high or auto fan)
- set the operation mode (fan only, cooling, heating)
- Possibility to use the T1 sensor as return air probe (mounted on the power unit)
- Possibility to use the T3 sensor as low temperature cut-out thermostat (mounted on the power unit)
- It allows to use the T2 sensor as Change-over (mounted on the power unit).
- time setting
- weekly ON/OFF program

Control power absorption: see the UP-Touch power unit

Dimensions: 110x72x25 mm

Power units and probes

UP-ECO power unit

Model	Code	ID
10-20-30-40-50	9071064	UP-ECO



Power unit for CB-E control.

Power unit to be installed on the end unit (fan coil interface) and it is an interlock for the connection with an external programmable thermostat for the ON/OFF mode activation.

- It controls the motor/the fan and the fan coil valve.
- It is connected to the electric supply.
- It receives the required information to manage such parts from the remote control (programmable thermostat)

Power unit absorption: 11 VA (6 W)

UP-Touch power unit

Model	Code	ID
10-20-30-40-50	9071065	UP-Touch



Power unit for CB-Touch, WM-AU and T-MB controls

Power unit to be installed on the end unit (fan coil interface).

- It controls the motor/the fan and the fan coil valve.
- It is connected to the electric supply.
- It receives the information required to manage such parts from the CB-Touch control, from the WM-AU or from the T-MB controls
- Possibility to use the T1 sensor (included) for the T1 function which allows the return air control.
- Possibility to use the T3 sensor (included) for the T3 function as water coil low temperature cut-out thermostat (summer and winter operation)
- Possibility to use the T2 sensor (included) for the T2 function which controls the summer/winter switch (change-over).

- It allows to control up to 10 units (1 master and 9 slaves).
- Max. network length: 100 meters.
- Max cable length between control and first connected power unit: 20 meters.

Power unit absorption: 11 VA (6 W)

T2 probe

Model	Code	ID
10-20-30-40-50	9025310	T2



Type NTC sensor, to be placed on the water supply pipe upstream 3 way valves (not to be used with 2 way valves).

The T2 probe is to be used as Change-Over for 2 pipe systems, for the automatic switch of the operation mode. If water temperature is lower than 20°C, cooling mode is set; on the other hand, if water temperature exceeds 30°C, heating mode is set

T1-T3 probe

Model	Code	ID
10-20-30-40-50	9071075	T1-T3



The kit consists of:

- N° 1 T1 sensor for return air control
- N° 1 T3 sensor to be used as low temperature cut-out thermostat

ACCESSORIES

Feet

Model	Code	ID
10-20-30-40-50	9071074	PAP-F

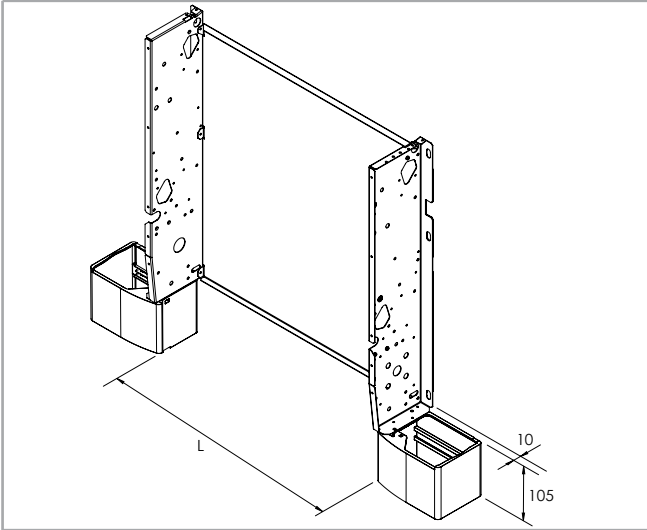

Model	CFF-ECM 10	CFF-ECM 20	CFF-ECM 30	CFF-ECM 40	CFF-ECM 50
D	300	500	700	900	1100

BREEZE frame kit for wall concealed installation

The kit is available in 3 sizes and allows the wall installation of the recessed Carisma Whisper CFF-ECM fan coil units.

The kit includes a top closing panel that prevents the access to technical spaces and coil ensuring the safety of the end user.

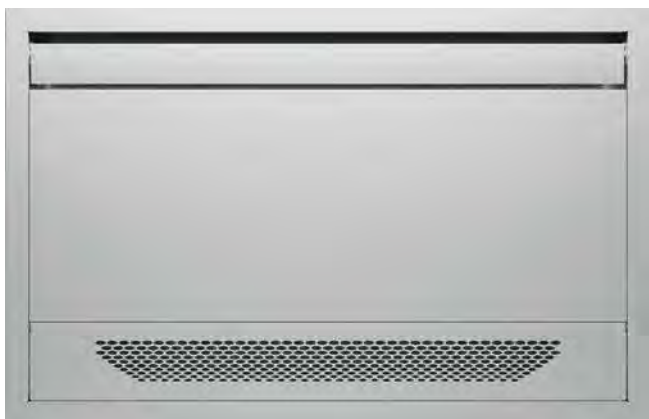

The aesthetic frame kit and the recessed box kit must be always combined together; the kits have separate codes because they are supplied in separate packagings.



The accessory can be used only for the CFF-ECM models, IV version, sizes 20-30-40.

In case of unit for concealed installation, the fan coil must be connected to a remote control and it is not possible to use controls fitted on the unit. With the Breeze kit it is not possible to install the valves of simplified type.

Constructional features of the main components

The aesthetic frame includes:

- the closing frame;
- the air supply louvre;
- the front panel;
- the air intake grid.

Perimeter frame, front panel and air intake grid made of steel painted with epoxy polyester coat, dried in a furnace at 180 °C, colour RAL 9003.

It is possible to repaint the entire frame of the same color as the wall.



The air supply louvre is made of extruded aluminium and painted with epoxy polyester coat, dried in a furnace at 180 °C, colour RAL 9003.



The air intake grid is fixed to the frame by using a simple and fast connecting system.

The grid can be easily removed to clean the filter and the inner casing.



The recessed box is made of galvanized steel with openings for the electrical and hydraulic connections.

To fit in the unit easily, there are 4 grub screws.



Aesthetic frame dimensions

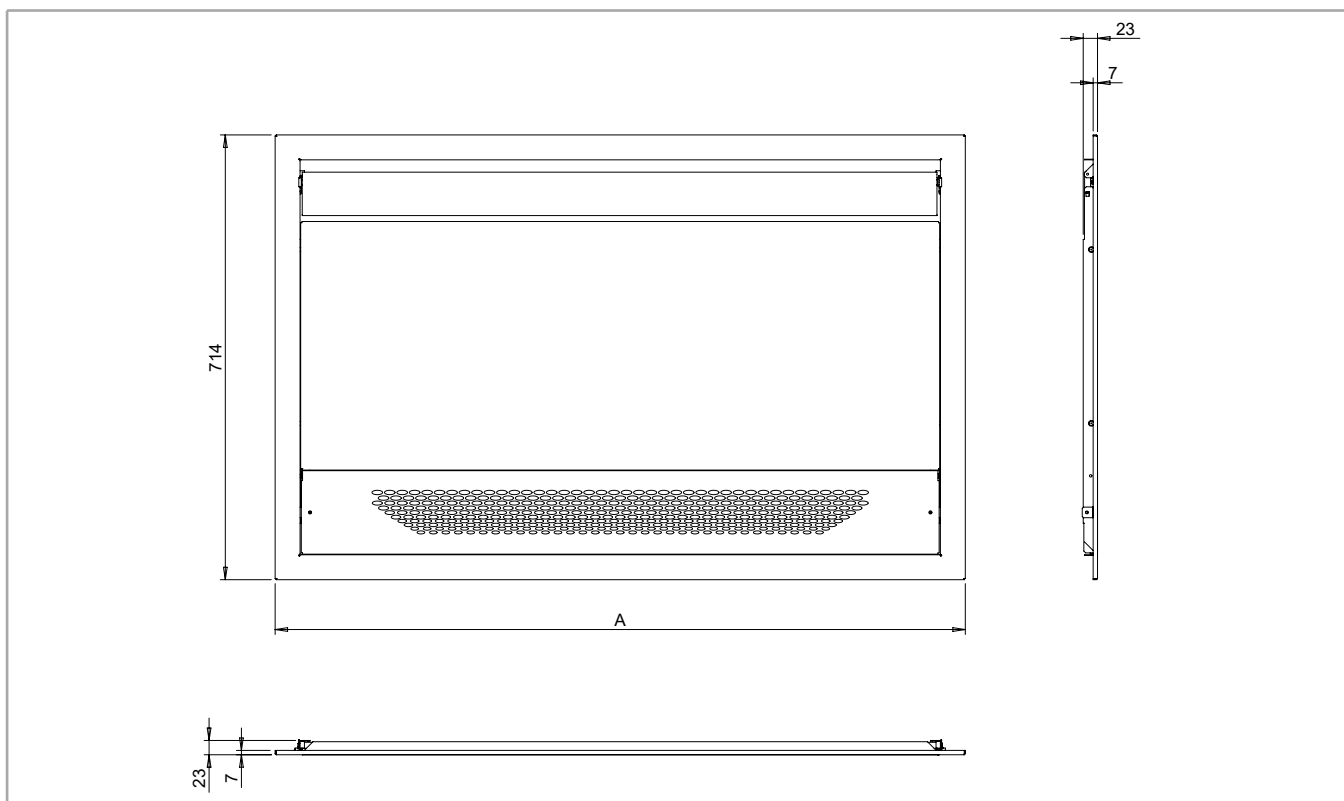

Model	A	Code	ID
CFF-ECM 20	908	9071162	CBF-A
CFF-ECM 30	1108	9071163	CBF-B
CFF-ECM 40	1308	9071164	CBF-C



Recessed box dimensions

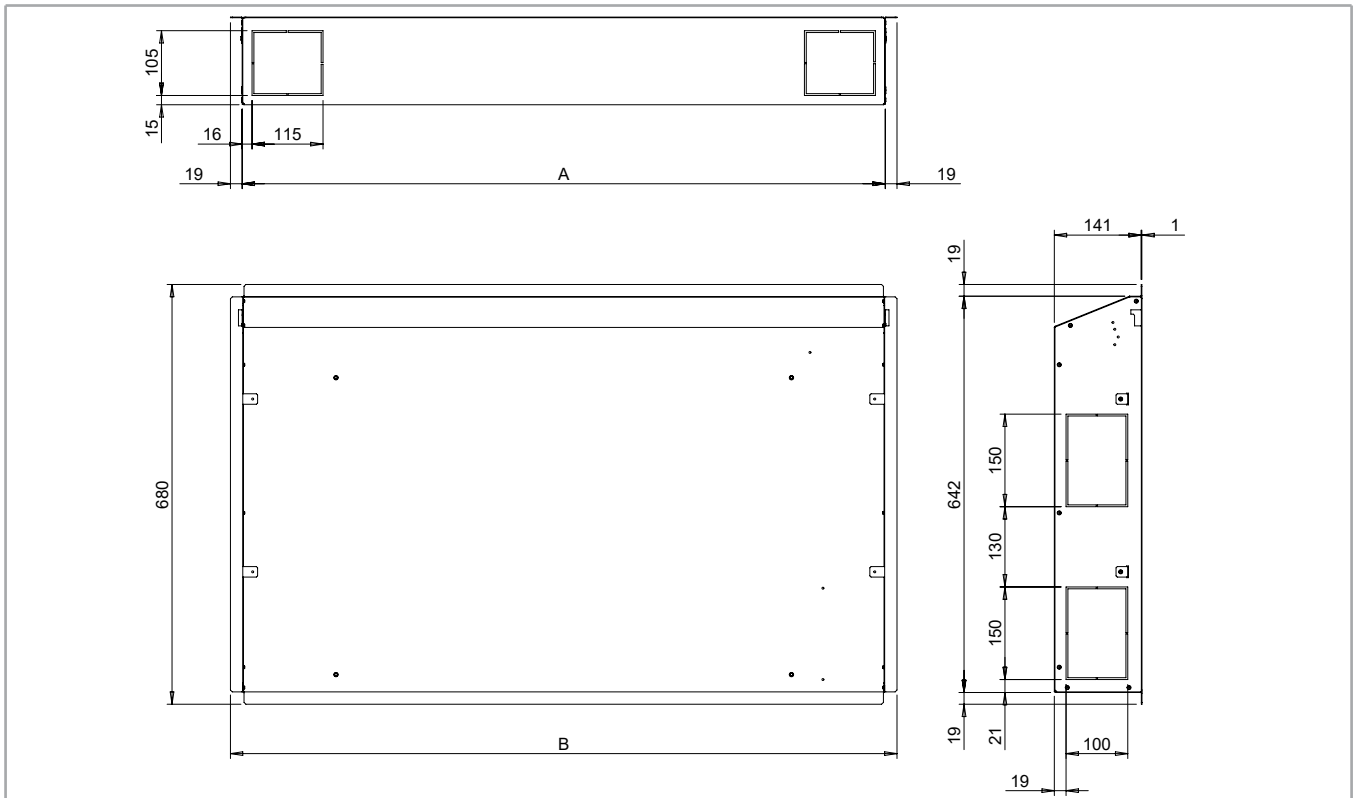

Model	A	B	Code	ID
CFF-ECM 20	842	880	9071152	IBF 2
CFF-ECM 30	1042	1080	9071153	IBF 3
CFF-ECM 40	1242	1280	9071154	IBF 4







CERTIFICATO n. 0545/7
 CERTIFICATE No. _____

SI CERTIFICA CHE IL SISTEMA DI GESTIONE PER LA QUALITÀ DI
 WE HEREBY CERTIFY THAT THE QUALITY MANAGEMENT SYSTEM OPERATED BY

SABIANA S.p.A.

Sede e Unità Operativa: Via Piave, 53 - 20011 Corbetta (MI)
 Direzione e uffici amministrativi, progettazione, produzione di apparecchiature per il riscaldamento e il condizionamento dell'aria (aerotermi, termostrisce radianti, unità trattamento aria) e canne fumarie.

Unità Operativa: Via Virgilio, 2 - 20013 Magenta (MI)
 Produzione di ventilconvettori, magazzino e logistica

Italia

È CONFORME ALLA NORMA / IS IN COMPLIANCE WITH THE STANDARD

UNI EN ISO 9001:2015

Sistema di Gestione per la Qualità / Quality Management System

PER LE SEGUENTI ATTIVITÀ / FOR THE FOLLOWING ACTIVITIES

EA: 18

Progettazione, produzione e assistenza di apparecchiature per il riscaldamento e il condizionamento dell'aria (aerotermi, termostrisce radianti, ventilconvettori e unità trattamento aria) e canne fumarie.

Design, production and service of heating and air conditioning equipment (unit heaters, radiant panels, fan coil units and air handling units) and chimneys.

Riferirsi alla documentazione del Sistema di Gestione per la Qualità aziendale per l'applicabilità dei requisiti della norma di riferimento.
 Refer to the documentation of the Quality Management System for details of application to reference standard requirements.

Il presente certificato è soggetto ai requisiti del documento ICIM "Regolamento per la certificazione dei sistemi di gestione" e al relativo Schema specifico.
 The use and the validity of this certificate shall satisfy the requirements of the ICIM document "Rules for the certification of company management systems" and specific Scheme.

Per informazioni puntuali e aggiornate circa eventuali variazioni intervenute nello stato della certificazione di cui al presente certificato, si prega di contattare il n° telefonico +39 02 725341 o indirizzo e-mail info@icim.it.

For timely and updated information about any changes in the certification status referred to in this certificate, please contact the number +39 02 725341 or email address info@icim.it.

Data emissione
 First issue
 10/06/1996

Emissione corrente
 Current issue
 10/04/2018

Data di scadenza
 Expiring date
 09/04/2021

ICIM S.p.A.

Piazza Dori Emico Mape, 75 - 20059 Sesto San Giovanni (MI)
 www.icim.it



SGQ N° 004 A PRD N° 004 B
 SGA N° 005 D PRS N° 082 C
 SGE N° 005 M ISP N° 046 E
 SCR N° 006 P ETS N° 003 D
 SSI N° 008 G EMAS N° 001 P

Membro degli Accordi di Mutuo Riconoscimento EA, IAF e ILAC
 Signatory of EA, IAF and ILAC Mutual Recognition Agreements



www.cisq.com

CISQ è la Federazione Italiana di Organismi di Certificazione dei sistemi di gestione aziendale.
 CISQ is the Italian Federation of management system Certification Bodies.

0145CM_03_IT

The descriptions and illustrations provided in this publication are not binding: **Sabiana** reserves the right, whilst maintaining the essential characteristics of the types described and illustrated, to make, at any time, without the requirement to promptly update this piece of literature, any changes that it considers useful for the purpose of improvement or for any other manufacturing or commercial requirements.



A company of Arbonia Group
ARBONIA 

Follow us on



Sabiana app



SABIANA SpA

Società a socio unico
via Piave 53 - 20011 Corbetta (MI) Italy
T. +39 02 97203 1 r.a. - F. +39 02 9777282
info@sabiana.it

www.sabiana.it